

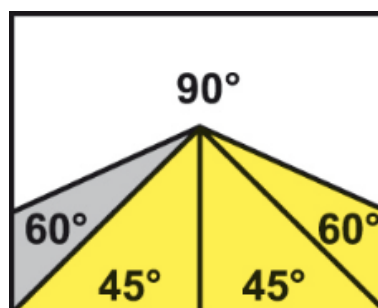

## ARG 200 PLUS

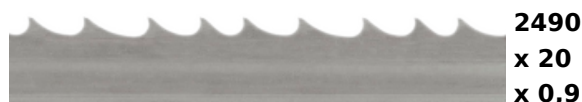

A universal band saw is appraised for general use in various workshops (work on locks, maintenance) and at plants with machinery. Band 20 x 0.9 mm allows for wide use when cutting sections and medium-sized full materials.





**Category:** [Descente assistée](#)

## PRODUCT DESCRIPTION

The band saw arm uplift is manual; the feed into cut is carried out by the weight of the arm, with the possibility of continuous regulation by the oil damper butterfly valve. When the cut is finished the band saw drive automatically switches off. To facilitate easy arm uplift the machine is equipped with adjustable tension springs that allow for setting of optimum force required for the arm uplift according to characteristics of the material to be cut.

Vice system provides bilateral continuous setting of the cutting angle within the ranges 60° to the right and 45° to the left. The turntable rotates along with the saw band. Thanks to that the saw band does not cut into the loading surface of the vice.

- Robust machine framework composes of castings from grey cast iron and therefore ensures vibration absorption.
- Modern concept of the band saw arm allows for large cutting ranges in upright and angular cuts.
- Simple locking and adjusting of the desired cutting angle on the angle scale with stops fixed at 45°, 60° and 90°.
- Massive quick-clamping vice ensures easy and reliable material clamping.
- Maximum cutting accuracy and saw band service life in this category of band saws.
- High-precision three-side hardmetal band saw guidance.
- Overdesign of running wheel bearings, tensioning wheel system and all rotary parts ensures long service life of the machine.
- Noiseless and maintenance-free band drive is provided by an industrial electric motor with worm gearbox.
- Three-phase two-speed motor (400 V) allows for the selection of band speed between 40 and 80 m/min.
- The machine is connected to a complete cooling system with a high-performance pump and possibility of regulating the flow on both guiding heads independently. Coolant tank with a pump is placed in the base of the machine.



Constructeur français  
de moyens de  
trouçonnage standards  
et spéciaux.

## FICHE TECHNIQUE

ARG 200 PLUS

<https://www.coup-indus.fr/produit/arg-200-plus/>

- Easy control by ergonomically placed controls (electrical and hydraulics) on the base of the machine.
- The machine is equipped with a 250 mm workpiece stop.



	90°	-45°	+45°	+60°
●	200	135	155	95
■	200	115	130	65
■	250 x 140	150 x 70	160 x 125	100 x 60

Main motor	400 V, 50 Hz, 0,75/0,95 kW
Pump motor	400 V, 50 Hz, 0,05 kW
Saw blade speed	40/80 m/min.
Working height of vice	900 mm
Coolant tank	cca 15 l
Machine dimensions (min.)	1430 x 750 x 1400 mm
Machine dimensions (max.)	1450 x 1280 x 1980 mm
Machine weight	245 kg

Convoyeurs disponibles:

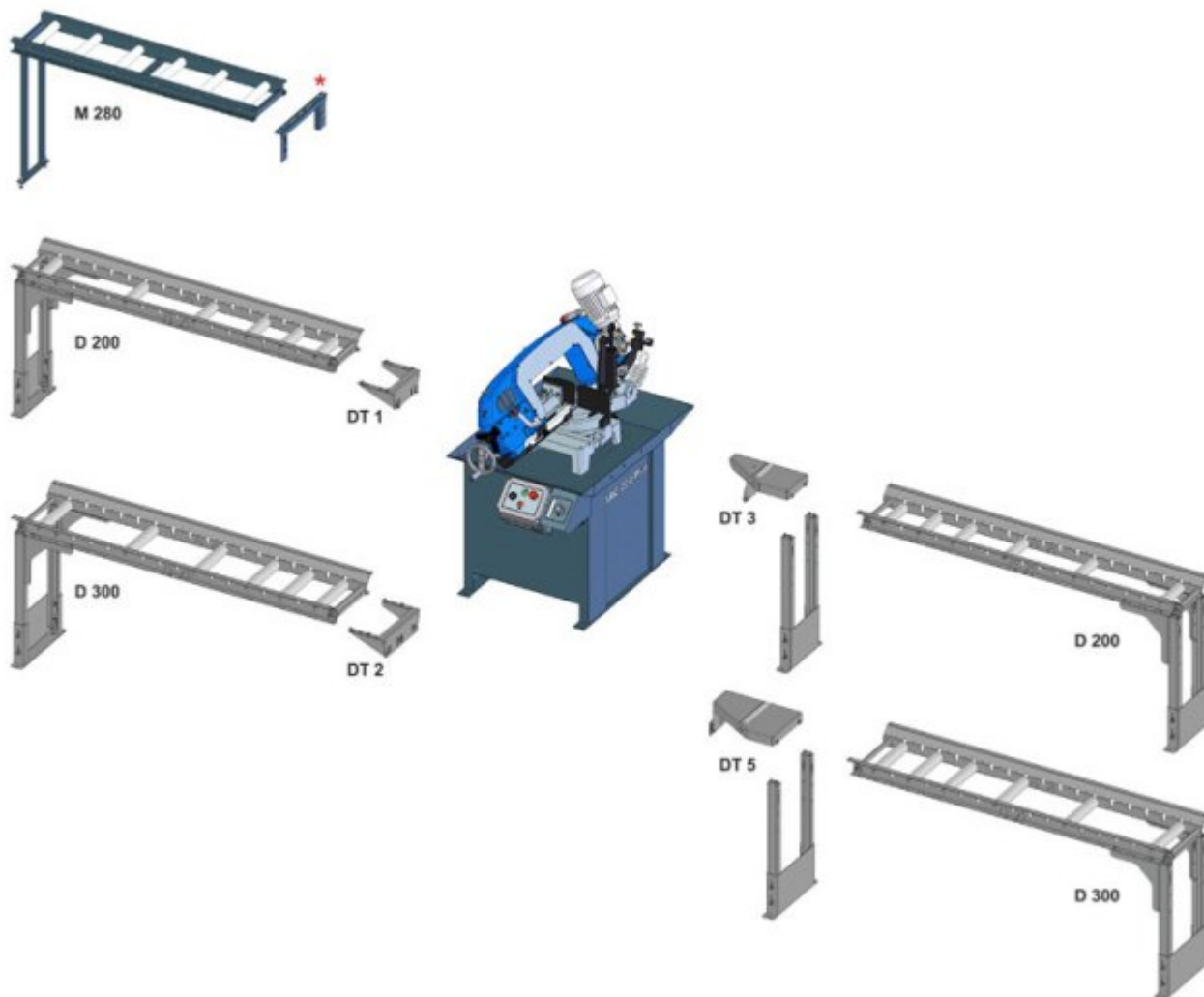

### Workpiece stop - Standard equipment

Simple stop for setting the required length of the material to be cut.



### Pressure device

Used to clamp the bundles of material to be cut. Ensures simple and reliable material clamping using a vertical contact pressure.



### Halogen lamp

Provides good lighting of the workplace of the machine. An invaluable tool especially when the lighting at the workplace is insufficient.



### Oil mist lubrication

Creates an oil mist that is sprayed onto the cutting edge. It replaces the use of a classic coolant, especially when cutting sections during which leakages may occur. Possibility of using organic oils.